

MultiHaul™ Base Unit B100 Product Description



Table of Contents

- 1. Introduction4
- 2. MultiHaul™ Base Unit B100 Overview7
 - 2.1 Functional Blocks.....7
 - 2.2 General Specifications8
 - 2.3 MultiHaul™ B100 Form Factor9
- 3. MultiHaul™ Base Unit B100 Specifications 10
 - 3.1 Point to Multipoint 10
 - 3.2 Scanning Antenna 10
 - 3.3 Continuous Align Antenna 10
 - 3.4 Adaptive Modulation and Coding 10
 - 3.5 Dynamic Capacity Allocation 10
 - 3.6 Integrated Ethernet switch 10
 - 3.7 OOB Operations..... 11
- 4. MultiHaul™ Base Unit B100 Networking Features 11
- 5. MultiHaul™ Base Unit B100 OAM features 11
- 6. MultiHaul™ Base Unit B100 Management Concepts..... 11
- 7. MultiHaul™ Base Unit B100 Power 11
 - 7.1 Power Input 11
 - 7.2 Power Output 12
- 8. MultiHaul™ Base Unit B100 Deployment Topologies..... 12
- 9. MultiHaul™ Base Unit B100 Standards Compliance 13
- 10. References 13

Document Information

Revision	Date	Author	Revision notes
2	10 December 2017	SH	Updated Release, aligned with System SW MH 2.0
1	10 April 2017	SH	Initial Release, aligned with System SW MH 1.0

Intended Audience

- Solution architects and network planning staff
- Telecom backhaul engineers
- Wireless ISP, business connectivity and wireless networks pre-sale engineers

Terminology used in this document assumes audience familiarity with millimeter wave radio communication and networking technologies.

Comments and suggestions are welcome to: info@siklu.com.

1. Introduction

This Product Description document details the special features of the MultiHaul™ Base Unit B100, in reference to MultiHaul™ family generic characteristics which are reviewed in a companion document, the MultiHaul™ System Description (reference [1]), also available on Siklu's partners' portal. The unique aspects are contained in this document, while the aspects common to the MultiHaul™ product lines are included by reference to the generic MultiHaul™ System Description document. The feature description assumes that the MultiHaul™ Base Unit is running Siklu system software MH1.0. The 2 documents can be reviewed in the order suitable to the reader.

The MultiHaul™ Base Unit B100 (MH-B100) radio delivers carrier-grade wireless point-to-multipoint Gigabit Ethernet services utilizing the 60 GHz un-licensed V band spectrum. The solution is designed for a range of last hop connectivity, from CCTV and Safe /Smart-City networks to Gigabit-to-the-Home. On one hand, the B100 meets the stringent requirements of service providers while on the other hand allows easy installation by non-Telco professional staff.

The B100 is based on Siklu's revolutionary integrated-silicon technology, which results in a highly reliable, zero footprint, and low-cost radio.

The B100 offers multi Gigabit throughput, enhanced adaptive coding & modulation for maximum spectral efficiency, and services availability. It supports complex network topologies, such as daisy chain, ring, and mesh. All in a very small and light outdoor package that is optimized for zero footprint installations and designed to overcome pole sway, twist and/or tilt. MultiHaul™ B100 is fast, simple and inexpensive to deploy.

- Point to Multipoint
 - Wide coverage, 1 to many
 - Pencil-thin narrow beams
- All-outdoor zero footprint
 - Small and light
 - Quick and very easy to install, with ZeroAlign
 - Siklu designed AnyMount bracket allow for installations on poles or flush on walls
- Optimized for variety of deployments, from street level to roof-top
 - Works on poles, buildings facades (walls), traffic lights and more
 - Designed to overcome sway, twist and/or tilt
- Field proven technology
- Reduced TCO and fast ROI
- Smart Radio
 - Adaptive coding and modulation for high availability

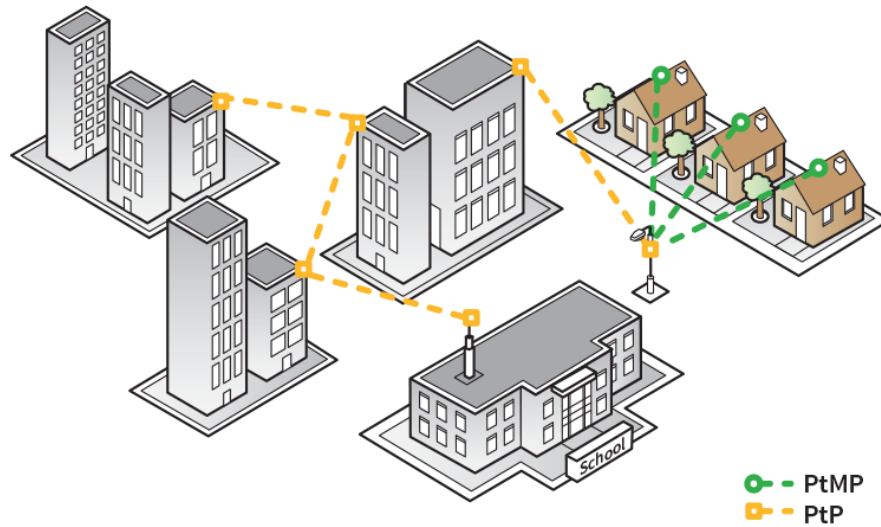

Figure 1: Gigabit Services



Figure 2: Campus Connectivity

Easily integrated into service-provider networks, out-of-the-box up & running capable, highly-scalable, the MultiHaul™ products are software-upgradable to support future capabilities as networks evolve.

The MultiHaul™ products features advanced adaptive modulation, bandwidth and coding - allowing operators to maintain connectivity in all weather conditions, while achieving maximum (up to 99.999%) link availability for prioritized services such as voice or control protocols.



Figure 3: MultiHaul™ B100 installed

Offering easy and low cost all-outdoor installation and a small form factor, the MultiHaul™ B100 are also environmentally-friendly - boasting a small system and antenna footprint with especially low power consumption.

The MultiHaul™ B100 are high-capacity Gigabit Ethernet aggregation at the lowest TCO in the industry. MultiHaul™ enables service providers to profitably and reliably provide data intensive services. Provided by Siklu, the pioneer in silicon based mm-waves backhaul systems, MultiHaul™ systems are the perfect choice for future proof investment.

2. MultiHaul™ Base Unit B100 Overview

2.1 Functional Blocks

The MultiHaul™ Base Unit B100 is an all-outdoor unit comprised of the following functional blocks:

- a. RF section: Siklu’s self-designed innovative multi-antenna array, powered by Silicon integrated transceivers and amplifiers.
- b. Modem/Baseband ASIC: a modem/baseband ASIC modem, capable of point to multipoint operations and management of the antenna array.
- c. Host processor integrated with the Ethernet switch: the general purpose host processor controls the system, and the Ethernet switch.
- d. Interfaces: 2 copper Ethernet ports, RJ-45, and 1 SFP cage.
- e. Power: is derived via PoE-In from Ethernet#1, regulated and delivered to the various blocks of the B100.

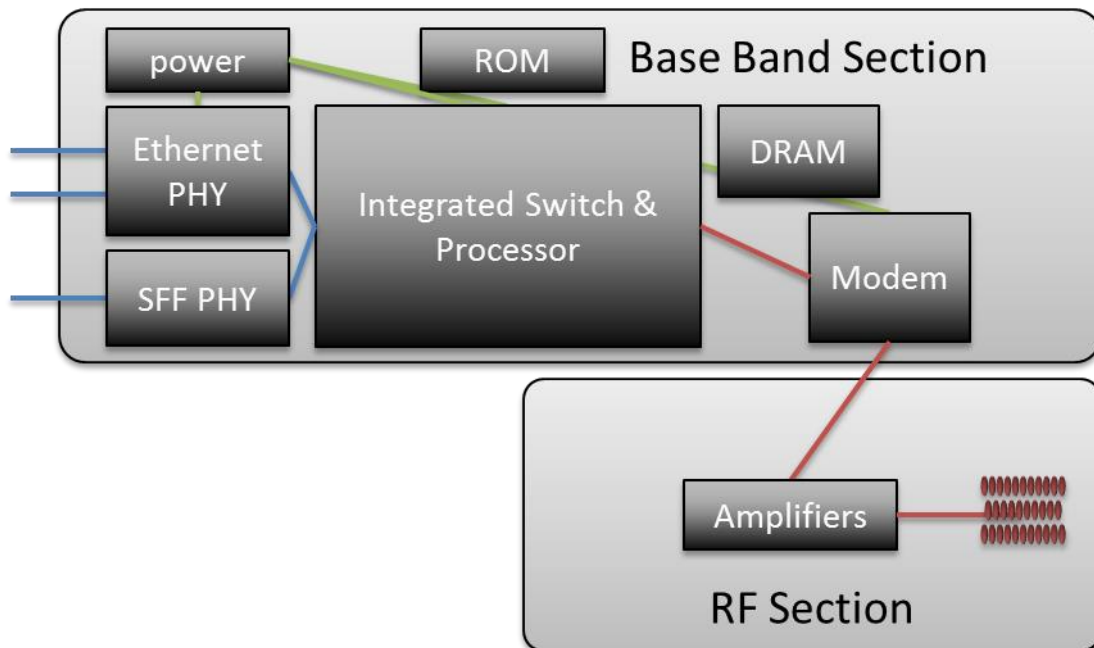

Figure 4: MultiHaul™ B100 Block Diagram

2.2 General Specifications

Parameter	Values															
Topologies	Point to Multi-Point (PtMP) and Point to Point (PtP)															
Frequency & Channels	57-64GHz ; 2x 2,160MHz channels (FCC plan) <table border="1" data-bbox="440 390 1466 573"> <thead> <tr> <th>Channel</th> <th>Band</th> <th>Min</th> <th>Max</th> <th>BW</th> </tr> </thead> <tbody> <tr> <td>2</td> <td>60.48 GHz</td> <td>59.4 GHz</td> <td>61.56 GHz</td> <td>2.16 GHz</td> </tr> <tr> <td>3</td> <td>62.64 GHz</td> <td>61.56 GHz</td> <td>63.72 GHz</td> <td>2.16 GHz</td> </tr> </tbody> </table>	Channel	Band	Min	Max	BW	2	60.48 GHz	59.4 GHz	61.56 GHz	2.16 GHz	3	62.64 GHz	61.56 GHz	63.72 GHz	2.16 GHz
Channel	Band	Min	Max	BW												
2	60.48 GHz	59.4 GHz	61.56 GHz	2.16 GHz												
3	62.64 GHz	61.56 GHz	63.72 GHz	2.16 GHz												
Channel Access	Channel Sense Multiple Access (CSMA)															
Modulation	BPSK/QPSK															
Maximum output power (EIRP)	40 dBm															
Air Interface PHY rate	Up to 2,300Mbps at highest modulation															
Over-the-air L2 throughput	Up to 1,800Mbps aggregated, dynamically allocated between up- and downstream															
Interfaces	2x 10/100/1000 Base-T, 1x SFP															
Antenna	Integrated MIMO antenna array, 90° wide horizontal scanning coverage Vertical beam width: 20° RX gain: 20 dBi (TX gain included in output power above)															
Power options	PoE-In on Ethernet#1: 10W, 802.3af when no PoE-Out 36W, 803.at+ when PoE-Out on Ethernet#2 PoE-Out on Ethernet#2: 802.3at (26W)															
Management	<ul style="list-style-type: none"> Out-of-band local management and over-the-air remote management, Web GUI (one click management of local & remote units), embedded CLI, SNMPv2/3, Zero-touch turn-up, TACACS+, RADIUS 															
Environmental	<ul style="list-style-type: none"> Operating temperature: 22°F ÷ 131°F (-30°C ÷ 55°C); optional -49°F ÷ 131°F (-45°C ÷ 55°C) Ingress protection rating: IP65; optional IP-67 NEMA rating: enclosure type 3; optional type 4 															
Regulatory	<ul style="list-style-type: none"> Radio: US FCC 47 CFR Part 15 subpart C & Japan Radio Ordinance 2-1-19-4-2 EMC: FCC 47 CFR Part 15 subpart B & EN 301 489 Safety: UL 60950 															
Dimensions	H x W x D: 7.5x5.2x3.5 in. (19.1x13.2x8.9cm)															
Weight	3lbs. (1.4kg), including AnyMount bracket															

2.3 MultiHaul™ B100 Form Factor

The MultiHaul™ B100 features a unique all-integrated form factor, as shown on Figure 5 (front view) and Figure 6 (rear view):



Figure 5: MultiHaul™ B100 - front view and LEDs

LED	Color	Status
RF	Green	RF Link UP
ETH1/2/3	Green	1Gbps
	Orange	10/100Mbps
PWR	Green – Power On	Blinking – boot up
	Orange - reboot	

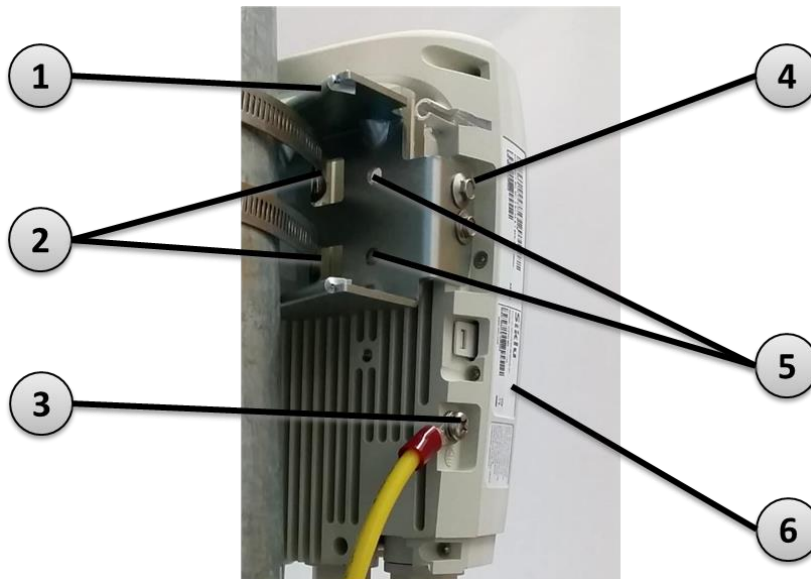

Figure 6: MultiHaul™ B100 - rear view

- 1) AnyMount mounting bracket (pole or wall mount)
- 2) Self-locking bands fixing points (4 points for 2 bands)

- 3) Grounding point
- 4) Elevation lock-bolts (2x 7mm on each side)
- 5) Wall-mount fixing holes (4 holes for 4 screws)
- 6) Label

3. MultiHaul™ Base Unit B100 Specifications

3.1 Point to Multipoint

MultiHaul™ introduces a new level of performance in 60GHz millimeter wave communications, by adding point-to-multipoint topologies. SW controlled beam-forming ensures a wide angle coverage and narrow beams for immunity and performance. Additional information is provided in the companion document “MultiHaul™ System Description”.

3.2 Scanning Antenna

MultiHaul™ units feature a compact integrated wide-sector horizontal scanning antenna, which auto-aligns the narrow-beam links between BU and TUs. Additional information is provided in the companion document “MultiHaul™ System Description”.

3.3 Continuous Align Antenna

MultiHaul™ BU and TUs continuously align and re-align links. Additional information is provided in the companion document “MultiHaul™ System Description”.

3.4 Adaptive Modulation and Coding

MultiHaul™ implements adaptive coding and modulation adjustments to optimize the over-the-air transmission and prevent weather-related fading traffic interruptions. Additional information is provided in the companion document “MultiHaul™ System Description”.

3.5 Dynamic Capacity Allocation

MultiHaul™ continuously assigns dynamically the licensed capacity between the Base Unit and the Terminal Units, between the downstream and the upstream directions, for optimal user experience per the changing needs and traffic patterns of the services in actual use. Additional information is provided in the companion document “MultiHaul™ System Description”.

3.6 Integrated Ethernet switch

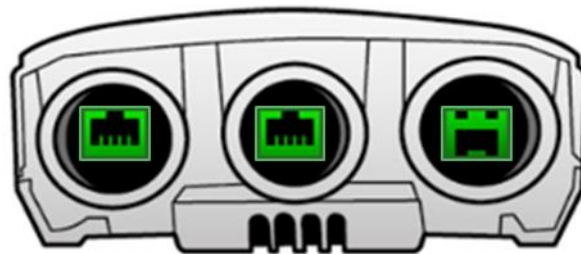

Figure 7: MultiHaul™ B100 ports

The 3 ports of the MultiHaul™ B100 integrated Gigabit Ethernet switch are shown on Figure 7, and include from left to right:

- Ethernet #1 is a 10/100/1000 Base-T compliant port, with power in
- Ethernet #2 is a 10/100/1000 Base-T compliant port, with power output per IEEE 802.3at

- Ethernet #3 is an SFF MSA compliant cage. The Siklu offered and 3rd party recommended devices can operate at 1Gbps (default) and can be configured for operations at 2.5Gbps.

Each port can be configured to support:

- Auto negotiation enabled/disabled
- Speeds: 100/1000/2500 Mbps (port dependent).
- Full-duplex / half-duplex
- Delivery of both payload traffic and/or management traffic (see networking)

3.6.1 Benefits

- 1 or 2 Gigabit Ethernet ports on the BU are an ideal number of interfaces at a hub site, where the ports connected can match the network needs flexibly. This enables:
 - 1 or 2 GigE ports can deliver the full payload over copper/CAT5 cable
 - 1 optical port can be configured at 1GigE or 2.5GigE to deliver the full payload over longer reach, without incurring the cost of expansive 10G interfaces.
 - Daisy-chain of traffic through several Base Units to simplify site cabling (a BU can also power 2 other BUs in the chain)

3.7 OOB Operations

While MultiHaul™ is a very sophisticated product, it is very simple to deploy and operate. Additional information is provided in the companion document “MultiHaul™ System Description”.

4. MultiHaul™ Base Unit B100 Networking Features

Full details are provided in the companion document “MultiHaul™ System Description”.

5. MultiHaul™ Base Unit B100 OAM features

Full details are provided in the companion document “MultiHaul™ System Description”.

6. MultiHaul™ Base Unit B100 Management Concepts

Full details are provided in the companion document “MultiHaul™ System Description”.

7. MultiHaul™ Base Unit B100 Power

7.1 Power Input

The MultiHaul™ simplifies powering the unit by leveraging the data cable of Ethernet#1 for power, with the standard Power Over Ethernet concept, 802.3af or 802.3at+, implementation dependent.

Parameter	Values	Comments
Voltage input	42 ÷ 57 VDC	
Power draw	10W, 802.3af	No PoE-Out
Power draw	40W, 802.3at+	PoE-Out on Ethernet#2

7.2 Power Output

The MultiHaul™ Base Unit B100 supports PoE-Out:

Port	Values	Comments
Ethernet #2	26W, 802.3af	

8. MultiHaul™ Base Unit B100 Deployment Topologies

Full details are provided in the companion document “MultiHaul™ System Description”.

9. MultiHaul™ Base Unit B100 Standards Compliance

The list of standards and recommendations supported generically by MultiHaul™ software and hardware is:

Management (reference also to Security)

- RFC 1157 SNMPv2/3
- RFC 2131 - Dynamic Host Configuration Protocol
- RFC2819 – RMON Remote Network MONitoring

Security

- IETF TACACS+
- RADIUS
- RFC 2246 - Transport Layer Security (TLS) protocol
- RFC 7230 - HTTPS, HTTP over TLS
- RFC 4251 - the IETF extension of the Secure Shell protocol (SSH) version 2.0
- RFC 913 - SFTP, SFTP, TFTP
- U.S. FIPS PUB 197 (FIPS 197), AES with 128 bits
- RFC2616 - Hypertext Transfer Protocol (HTTP)
- IEEE 802.1x

Networking

- IEEE 802.1ad - Provider Bridge, QinQ VLAN/VLAN stacking
- IEEE 802.1d - Transparent Bridge
- IEEE 802.3ab - Ethernet 1000BASE-T
- IEEE 802.1p - Traffic management (L2)
- IEEE 802.1ab - Link Layer Discovery Protocol (LLDP)
- MSA SFP INF-8074 Small Form Factor Pluggable

Environmental, Power

- CE: CE Marked
- EMC: FCC 47 CFR Part 15 subpart B & EN 301 489
- IEEE 802.3af or 802.3at PoE power source (model dependent)
- IEEE 802.3at++ PoE power(ed) device (model dependent)
- Ingress Protection Rating: IP65 (IP67 as a factory order option)
- NEMA rating: enclosure type 3 (type 4 as a factory order options)
- Operation: EN 300 019-1-4 Class 4.1E
- Safety: UL 60950
- Storage: EN 300 019-1-1 Class 1.2
- Transportation: EN 300 019-1-2 Class 2.2

Radio

- US: US FCC 47 CFR Part 15 subpart C
- Japan: Radio Equipment Certification Ordinance 2-1-19-4-2

10. References

- [1] Siklu' MultiHaul™ System Description, Release 3.0, December 2017

About Siklu

Siklu delivers Gigabit capacity millimeter wave wireless backhaul solutions operating in the 60, 70 and 80 GHz bands. Ideal for dense, capacity-hungry urban security networks, the ultra-high capacity wireless links can be easily and discreetly installed on the very same street fixtures as the security cameras. The most deployed mmW radios in the world, thousands of units are delivering carrier grade performance in varying weather conditions around the world.

